

- SPECIFICATION:**
1. Concrete: Has a Design Strength of 5,000 psi at 28 Days.
  2. Steel Reinforcement: ASTM A-815, Grade 60.
  3. Loading: Designed for H2O Loading.
  4. C.I. Casting: ASTM A48, Class 30/35.

- GENERAL NOTES:**
1. Unit Comes with Interior Inflow Piping Installed.
  2. Inflow Section of Unit Must be Filled with at Least 12" of Clear Water Prior to Use.

- FEATURES:**
- 4" Dia. P.V.C. Double Hub Inlet Furnished. Cast Iron Optional.
  - 4" Dia. P.V.C. Half Hub Outlet Furnished. Cast Iron Optional

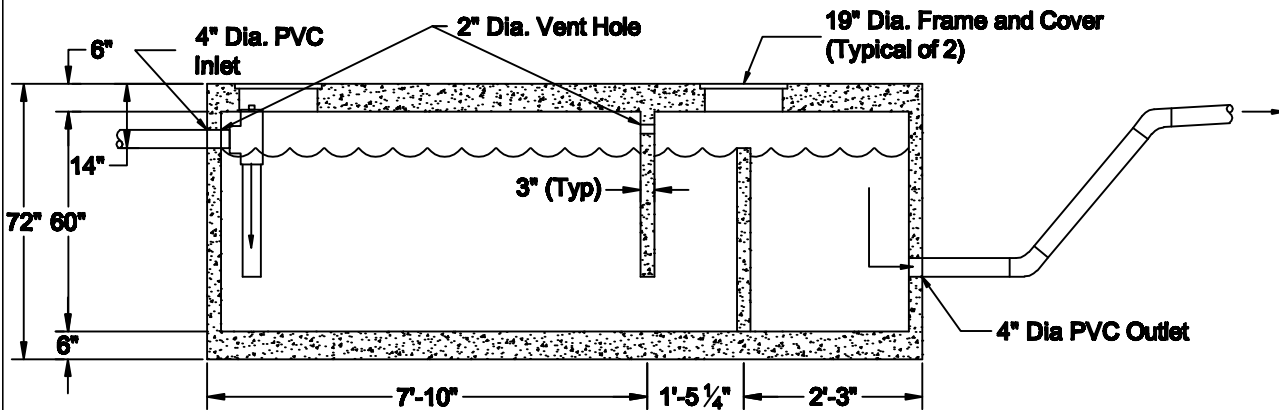

**SECTION A-A**

**SCALE: NTS**

SOUTHERN PRECAST CONCRETE PRODUCTS, INC.  
 6868 FM 730 S. AZLE, TX 76020  
 817.448.9718 PH  
 817.448.9886 FX  
 sw653@aol.com

**SPCP-GT-1500**

FILE NAME: 2009-1500GT

ISSUE DATE: MARCH 2009

**4'-7" x 11'-1/4" x 60" I.D.  
 1500 Gallon  
 Grease Trap**