

**PLAN VIEW**

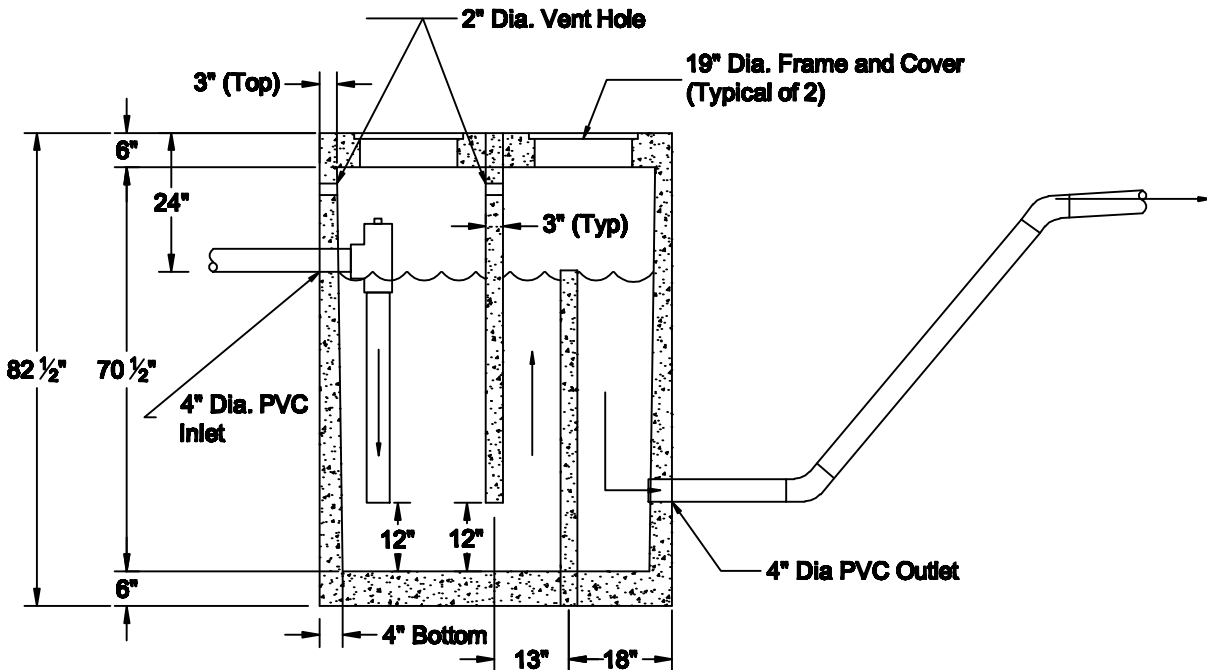

**SECTION A-A**

**SCALE: NTS**

- SPECIFICATION:**
1. Concrete: Has a Design Strength of 5,000 psi at 28 Days.
  2. Steel Reinforcement: ASTM A-815, Grade 60 or ASTM A-497 Welded Wire Fabric.
  3. Loading: Designed for H2O Loading.
  4. C.I. Casting: ASTM A48, Class 30/35.
- GENERAL NOTES:**
1. Unit Comes with Interior Inflow Piping Installed.
  2. Inflow Section of Unit Must be Filled with at Least 12" of Clear Water Prior to Use.
- FEATURES:**
- 4" Dia. P.V.C. Double Hub Inlet Furnished. Cast Iron Optional.
  - 4" Dia. P.V.C. Half Hub Outlet Furnished. Cast Iron Optional

SOUTHERN PRECAST CONCRETE PRODUCTS, INC.  
 6868 FM 730 S. AZLE, TX 76020  
 817.448.9718 PH  
 817.448.9886 FX  
 sw953@aol.com

**SPCP-GT-500**  
 FILE NAME: 2009-500GT  
 ISSUE DATE: MARCH 2009

**55 1/2" x 55 1/2" x 70 1/2" I.D.**  
**500 Gallon**  
**Grease Trap**