

- SPECIFICATION:**
- Concrete: Has a Design Strength of 5,000 psi at 28 Days.
 - Steel Reinforcement: ASTM A-815, Grade 60.
 - Loading: Designed for H2O Loading.
 - C.I. Casting: ASTM A48, Class 30/35.
- GENERAL NOTES:**
- Unit Comes with Interior Inflow Piping Installed.
 - Inflow Section of Unit Must be Filled with at Least 12" of Clear Water Prior to Use.
- FEATURES:**
- 4" Dia. P.V.C. Double Hub Inlet Furnished. Cast Iron Optional.
 - 4" Dia. P.V.C. Half Hub Outlet Furnished. Cast Iron Optional

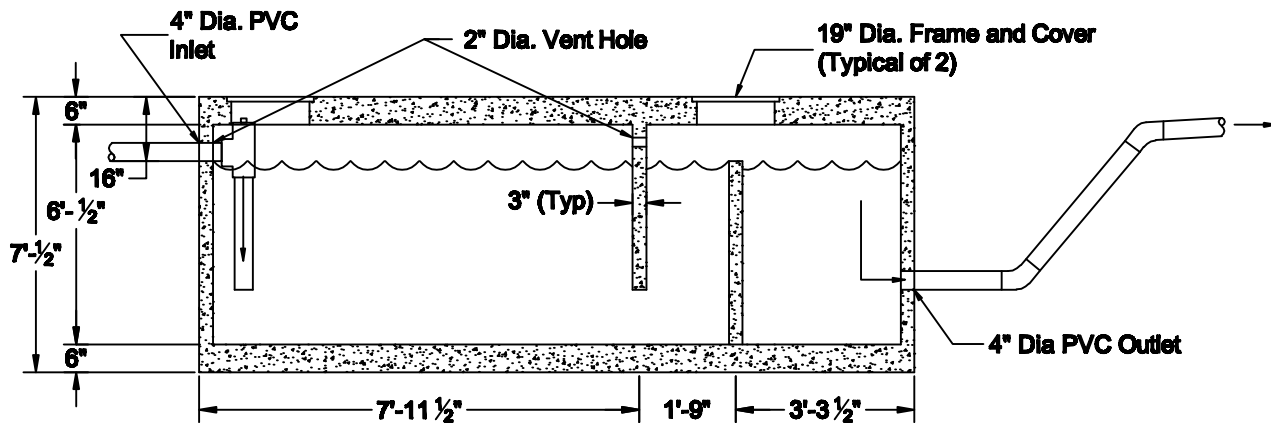

SCALE: NTS

SOUTHERN PRECAST CONCRETE PRODUCTS, INC.
 6866 FM 730 S. AZLE, TX 76020
 817.448.9718 PH
 817.448.9896 FX
 sw953@aol.com

SPCP-GT-2000

FILE NAME: 2009-2000GT

ISSUE DATE: MARCH 2009

**55 1/2" x 12'-6" x 6'-1/2" I.D.
 2000 Gallon
 Grease Trap**